

The multi-layer core design delivers therapeutic comfort

The PREMA Ward (Pressure REducing MAttress) offers patients enhanced levels of comfort and care from its multi-layer core design. The mattress can be reversible and rotatable to maximise its service life.

The waterproof and bielastic outer cover is breathable, antimicrobial and fire retardent. All seams are welded and a water resistant zip allows easy maintenance.

The materials used are resistant to a range of cleaners and disinfectants including 0.1% sodium hypochlorite. Asset management and auditing are made easier using the on-product information annotation areas.

FEATURES

- High quality multi-layer foams with superior cell structure
- Improved airflow through the mattress
- Waterproof, pliable, breathable and antimicrobial outer cover
- Welded seams with a water resistant zip around 3 sides
- X-ray radiolucent foam and cover materials
- Mattress cover tested to Oeko-Tex Standard®100
- Latex free

OPTIONS

- Compatible bolster mattress for M9 WARD bed extension
- Shorter PREMA Compact version is available



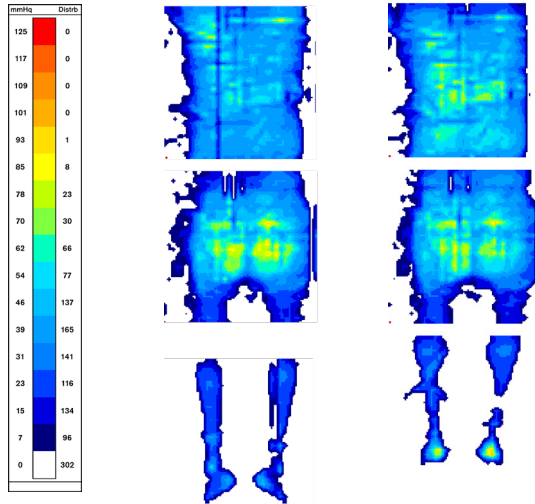

Lying flat and semi-recumbent, 62kg subject

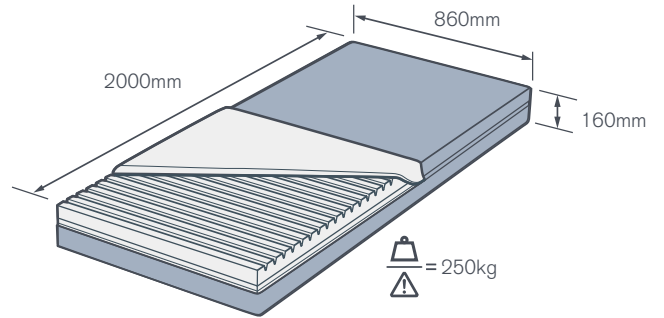

SPECIFICATIONS

MODEL:	PREMA WARD
PART NUMBER:	HC00103
MAXIMUM SWL:	250kg
MATTRESS MASS:	14kg

COVER MATERIAL

- Material type: bielastic
- Composition: 62% PA, 38% PU by weight
- Stretch: 2 way
- Tear strength: 55N warp, 60N weft
- Removable: yes
- Hydrostatic head test: >2m class DIN53.866
- Water resistant: yes
- Bacteria and mite resistant: yes
- Urine and blood resistant: yes
- Air and vapour permeable: yes
- Cleaning: yes

FOAM CORE

- Number of layers: 3
- Surface profile: grooves
- Density: 50/38/50 kg/m³
- Hardness: 120/200/120 N
- Cleaning: not to be cleaned

MATTRESS COMPLETE

- Skin friction & shear risk: low
- Fire retardant BS7177:1996 medium hazard
- Ergocheck pressure test, % of cells >32mmHg: <7% (averaged over 66 - 140kg weight range)
- Comfort: high
- Anti static: no
- Directional: no
- Sides for use: 2

DIMENSIONS

- PREMA Ward Mattress: L:2000mm, W:860mm, D:160mm

www.howardwrightcares.co.uk



Design and Development, Production, Sales, Distribution and Servicing of Medical Beds, Stretchers and Accessories

Howard Wright Limited has a policy of continuous product improvement and reserves the right to change product specifications without notice. Howard Wright Limited is certified to ISO13485:2016 © Howard Wright Limited, 2019

